

ORION[★] 160K

POWER, PERFORMANCE & PRECISION

160,000 lbs. maximum capacity [72,500 kgs.]



- Orion's quick-change attachment systems
- Durable components, long dependable life.
- Smooth, controlled hydrostatic drive
- Powerful V8, LP power
- **Made in Canada** 🇨🇦



highreachinc.com

orionlifts.com

ORION 160K

POWER, PERFORMANCE & PRECISION

Component Weights:

Chassis w/forks & all ctwts:	125,000 lbs.	Forks/carriage:	10,100 lbs.
Front:	38,960 lbs.	Boom:	15,360 lbs.
Rear:	86,040 lbs.	Boom & Stand:	17,288 lbs.
Chassis w/forks & w/o ctwts:	65,000 lbs.	Counterweights:	6,000lbs. x 10
Front:	38,960 lbs.	Total Ctwts:	60,000 lbs.
Rear:	26,040 lbs.		

Boom Specifications

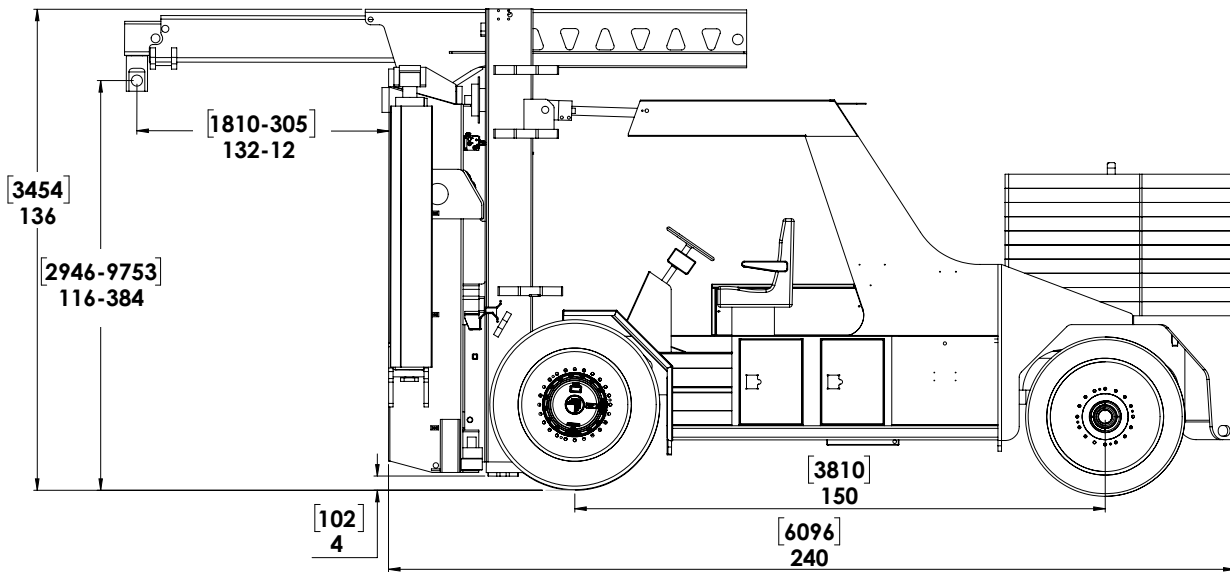

Rated Boom Capacities (lbs.)											
LC in Inches >	12"	24"	36"	48"	60"	72"	84"	96"	108"	120"	132"
0 CWT	48,710	40,970	35,350	31,090	27,740	25,040	22,830	20,970	19,390	18,030	16,860
2 CWT	72,490	60,970	52,610	46,260	41,280	37,270	33,970	31,210	28,860	26,840	25,080
4 CWT	96,270	80,970	69,860	61,440	54,820	49,500	45,110	41,440	38,330	35,640	33,310
6 CWT	120,050	100,970	87,120	76,610	68,370	61,720	56,260	51,680	47,790	44,450	41,540
8 CWT	140,000	120,970	104,380	91,790	81,910	73,950	67,400	61,920	57,260	53,250	49,770
10 CWT	155,000	130,000	111,000	95,000	84,000	75,000	67,400	61,920	57,260	53,250	49,770

*CAPACITIES RATED WITH MAST VERTICAL

ORION 160K

POWER, PERFORMANCE & PRECISION

160,000 lbs. @ 24" w/Sideshift

115,000 lbs. @ 48" w/Sideshift

Lift Height (clear): 132"
 Free Lift: 50"
 Standard Forks dimensions: 96" x 12" x 6"
 Max distance between standard forks: 71"
 Max distance outside-to-outside forks: 95"
 Min distance between forks: 5"
 Max lift height w/boom: 32"
 Max horizontal reach w/boom: 132"
 Travel Height: 136"

Overall Width: 102"
 Overall Length: 230"
 Wheelbase: 150"
 Engine/Fuel: 5.7L V-8 GM LP Industrial
 Hydrostatic Pump: Danfoss
 Gradability: 20% Loaded, 60% Unloaded
 Tires Front: 48" x 30" non-marking
 Tires Rear: 45" x 12" non-marking

Forklift Specifications

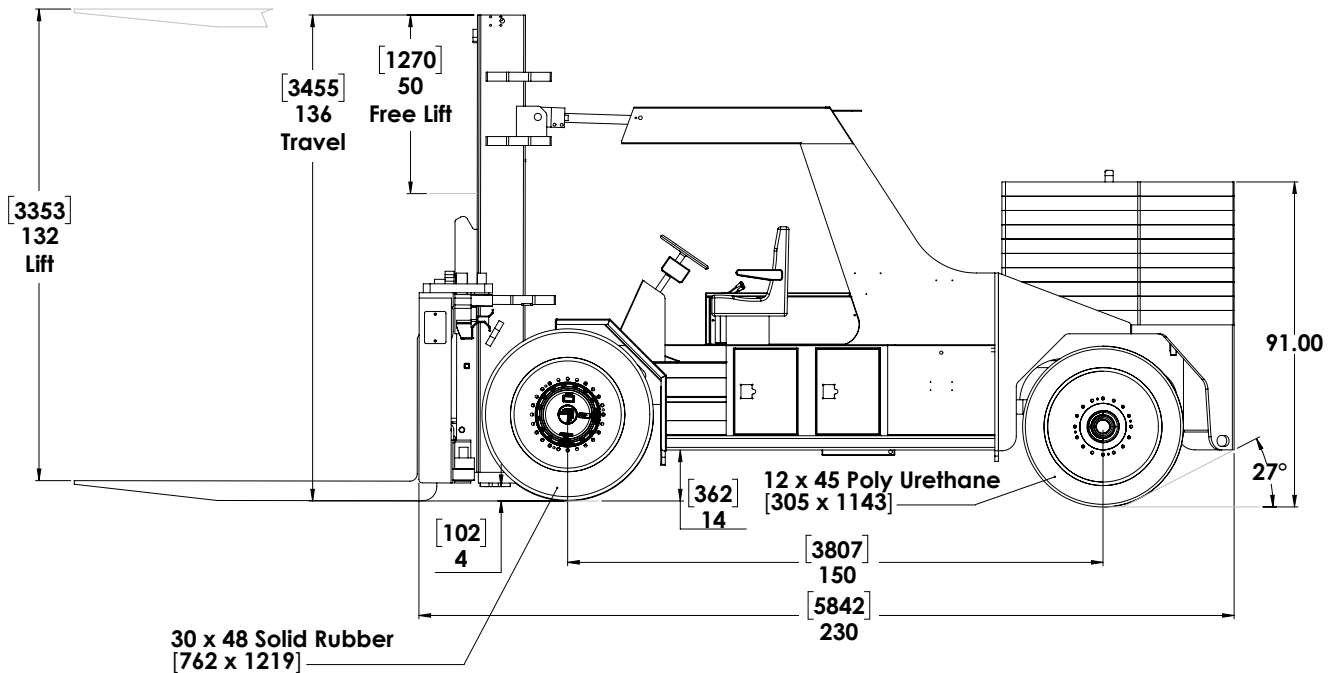

Rated Fork Capacities (lbs.)							
LC in Inches >	24"	36"	48"	60"	72"	84"	96"
0 CWT	49,770	42,010	36,350	32,030	28,630	25,880	23,610
2 CWT	72,850	61,490	53,200	46,880	41,900	37,880	34,560
4 CWT	95,920	80,970	70,060	61,730	55,180	49,880	45,510
6 CWT	119,000	100,450	86,910	76,580	68,450	61,880	56,460
8 CWT	142,080	119,940	103,760	91,340	81,730	73,940	67,510
10 CWT	160,000	133,000	115,000	103,000	81,730	73,940	67,510

*CAPACITIES RATED WITH MAST VERTICAL

ORION 160K

POWER, PERFORMANCE & PRECISION

ORION 160K features:

- ✓ The Orion Quick Change Riggers' Boom is safer and faster to install AND it improves boom lifting capacities.
- ✓ Full-power fork locators align the forks where you need them, when you need them, effortlessly.
- ✓ Tilt and roll angle sensors: Continuously monitor equipment orientation, ensuring safe operations and precise positioning every time.
- ✓ Easy-Read Electronic Load Scale: Instantly gauge the weight of your cargo with crystal-clear accuracy, ensuring safe and efficient operations every time.
- ✓ Rugged design and durable construction: Built to last with long-life components, ensuring consistent performance and reliability throughout its lifespan.

Optional Equipment:

- ✓ Variety in forks: Whether you need coil prong, coil forks, extra long forks, or another type, select the perfect fit for the task at hand, enhancing load versatility.
- ✓ Extra-wide/side-shifting custom carriages ensure precision in load placement and adaptability for diverse operations.
- ✓ Diesel Power - offers consistent performance and reliable, long-lasting operation.
- ✓ Operator's cab equipped with heating and AC: Stay comfortable and focused in any climate, ensuring efficient operations.
- ✓ Full-function Digital Radio Remote Control: Effortlessly steer, drive, and lift with unparalleled precision and from a safe distance.
- ✓ Front & backup cameras: Navigate with confidence, enhancing safety and minimizing risks in both forward and reverse directions.



Back up camera, back up alarm, among the safety features standard.



Easy-to-Use power fork locators for supporting different sized loads.



Very Low Lift LP Tank Loading. Improves safety immensely.



State-of-the-art electronic easy-read load scale.



High Reach Inc., 480 Wycroft Road, Oakville, Ontario, L6K 2G7 Canada
T: 905-844-4164 • www.highreachinc.com